

**Efficiency
meets durability.
We deliver
unmatched result.**

KINTA
MOBIFIELD
In-Field Agriculture Tractor



Built to last, designed for success. Discover a new level of productivity with our high-performance in-field machine.

Introducing Kinta Mobifield - the best solution for handling tough in-field terrain in the palm oil plantation. Our machine delivers exceptional performance and manoeuvrability, thanks to its advanced features and superior design. Built with the highest grade materials and components, its rugged construction and advanced design make it capable of handling any terrain, from steep hills to muddy fields. Invest in the future of your palm oil farm with Kinta Mobifield - the ultimate solution for success.



A true partner in your tractor ownership and maintenance solution.



www.allplanters.com.my

KINTA MOBIFIELD

MB30 IN-FIELD AGRICULTURE TRACTOR

Features:

- Articulating and oscillating body for enhanced manoeuvrability and stability
- Compatible with FFB Agri Grabber for efficient loading and unloading
- Heavy-duty frame and LGP (low ground pressure) tyres for durability and traction on various terrains
- Powerful engine with a higher net carrying capacity, allowing for more efficient transport of heavy loads



Engine HP	30HP Engine	Tyres	31x15.50-15 8PR (LGP)
Transmission	8 Forward, 2 Reverse	Tipping System	Hydraulic Spool Valve
Clutch	Single Dry Plate	Tipping Height	Max 7'8"
Max Load (kg)	1,250kg	Tank Capacity	30 Litre Diesel Tank
Reduction Unit	Double/Neutral All Time 4WD	FFB Grabber	2.1m or 2.8m option
PTO*	Independent Hydraulic PTO	Travelling speed	2.1-21km/hour
Frame	Central Oscillation Pivot $\pm 15^\circ$	Length (mm)	4,572mm
Steering	Hydraulic Orbital Steering	Width (mm)	1,625mm

*Optional Addon

Dimensions:

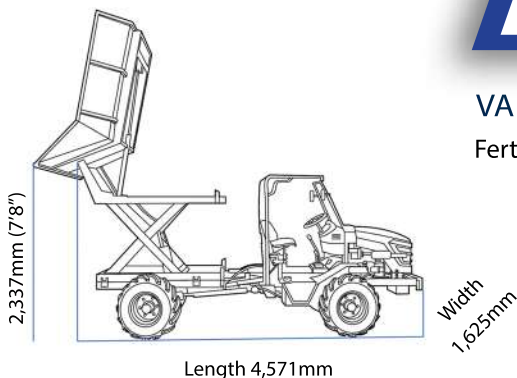

High 7'8" Unloading Height to Bin or Trailer



Articulating and Oscillating body

VARIOUS OPTIONS ARE AVAILABLE FOR MOBIFIELD:

Fertilizer Spreader, Sprayer, Flatbed Trailer, FFB Grabbers, 4WD or 6WD and more.

